

THIS DRAWING IS UNPUBLISHED. RELEASED FOR PUBLICATION
 © COPYRIGHT BY TYCO ELECTRONICS CORPORATION. ALL RIGHTS RESERVED.

LOC	DIST	REVISIONS					
G	14	P	LTR	DESCRIPTION	DATE	DWN	APVD
		L		REV PER 0G3A-0664-04	23AUG04	JR	TM

AMP WIRE RANGE	Listed FILE E13288	LR7189 Certified
22-16 AWG SOLID OR STRANDED	22-16 AWG SOLID OR STRANDED	22-16 AWG SOLID OR STRANDED

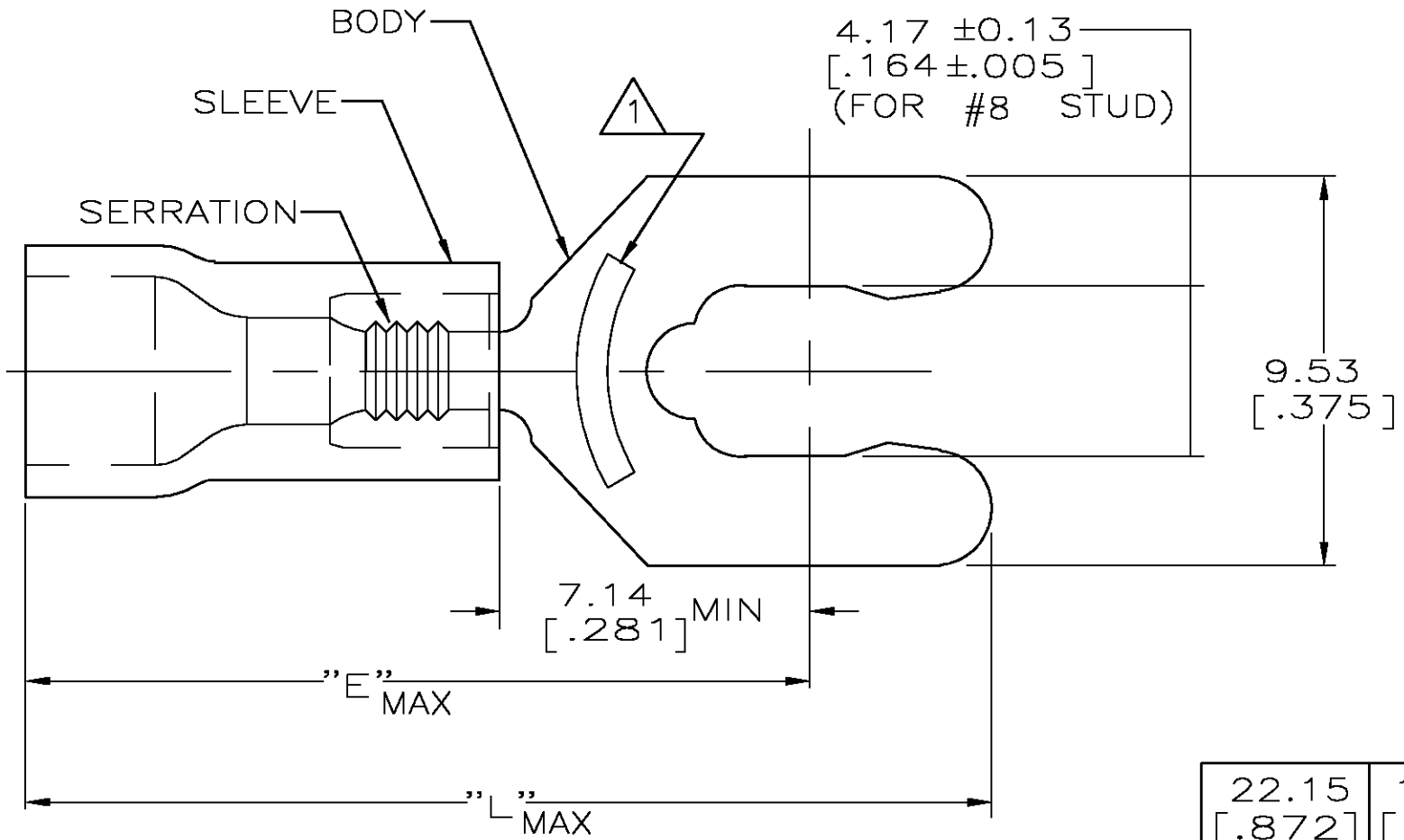

- △ 1 STAMP 8S AMP 22-18* APPROX AS SHOWN
22-16 TERMINALS ARE STAMPED 22-18 IN
ACCORDANCE WITH MILITARY SPEC MIL-T-7928
COMMERCIAL WIRE RANGE IS 22-16
- 2. SEE TABLE FOR WIRE INSUL DIA
- 3. TONGUE MATL THK, 0.79±0.05 [.031±.002]
- △ 4 MATERIAL: BODY - BRASS PER ASTM B36
SLEEVE - PVC, COLOR - RED

22.15 [.872]	17.70 [.697]	2.67-3.56 [.105-.140]	100	LOOSE PIECE, BOX	8-52950-1
23.39 [.921]	18.95 [.746]	3.81-5.08 [.150-.200]	2500	ON TAPE, REEL	52950-3
23.39 [.921]	18.95 [.746]	3.81-5.08 [.150-.200]	1000	LOOSE PIECE	52950-2
22.15 [.872]	17.70 [.697]	2.67-3.56 [.105-.140]	5000	ON TAPE, REEL	52950-1
22.15 [.872]	17.70 [.697]	2.67-3.56 [.105-.140]	1000	LOOSE PIECE	52950
L	E	WIRE INSUL DIA	QTY	PACKAGE TYPE	PART NO

AMP INCORPORATED CUSTOMER SERVICE SYSTEMS		MAX RECOMMENDED OPERATING TEMPERATURE: 105°C [221°F]	THIS DRAWING IS A CONTROLLED DOCUMENT.		DWN L OLMEDA 26JUN95	Tyco Electronics Corporation Harrisburg, Pa 17105-3608			
FOR ADDITIONAL PRODUCT INFORMATION OR COPIES OF DRAWINGS AND TECHNICAL DOCUMENTS	PRODUCT INFORMATION CENTER 1-800-522-6752	VOLTAGE RATING: 600V MAX (1000V FIXTURE OR SIGN)	DIMENSIONS: mm[INCHES]	TOLERANCES UNLESS OTHERWISE SPECIFIED:	CHK M ELLIS 26JUN95	NAME			
FOR APPLICATION TOOLING INFORMATION	TOOLING ASSISTANCE CENTER 1-800-722-1111	CIRCULAR MIL AREA: 0.26-1.65mm² [509-3260] SOLID OR STRANDED		0 PLC ± - 1 PLC ± - 2 PLC ± 0.20 [.008] 3 PLC ± - 4 PLC ± - ANGLES ± -	APVD G NGO 26JUN95	TERMINAL, SPRING SPADE, SHORT, PLASTI-GRIP, WIRE SIZE: 22-16			
FOR ORDER ENTRY	1-800-526-5142	THIS DRAWING IS A CONTROLLED DOCUMENT FOR AMP INCORPORATED. IT IS SUBJECT TO CHANGE AND THE CONTROLLING ENGINEERING ORGANIZATION SHOULD BE CONTACTED FOR THE LATEST REVISION.	MATERIAL - 4	FINISH TIN PER ASTM B545	PRODUCT SPEC UL 486A	SIZE A3	CAGE CODE 00779	DRAWING NO C-52950	RESTRICTED TO
CUSTOMER DRAWING					WEIGHT -	SCALE 6:1	SHEET 1 OF 1	REV L	